



HDS Heavy Duty Stationary

Big production in a small package!



The HDS frame is designed to be the most rigid stone splitter frame in the industry and carries the only lifetime guarantee. This rigidity allows all of the cutting force to be immediately transferred to the stone and not absorbed by the frame giving you superior splits and more power to cut the harder stones.



Available with Gas, EPA Compliant Kubota Diesel or Electric Power Supplies.

The **HDS** is a very tough and versatile production machine for splitting building stone or preparing stone for thin veneer sawing and is ideal as a compliment larger machine to split medium size boulders in a production line. The HDS has 26-inches of cutting teeth with a 32-inch wide and 16-inch high opening.

This durable and hard working unit is delivered complete for less than 50K and is a great return on investment. The floating Roller Inbound table and floating Steel Outbound table increases production by allowing the easy movement of stone between operator and off-bearer.

Features:

- 70 tons of stationary cutting force
- Process stone 32" wide up to 16" thick
- Lifetime guarantee on one-piece frame
- Fork lift holes for portability
- Optional conveyors available
- On-site installation and training included

For more information call or visit: 800-350-9313 www.CeeJayTool.com

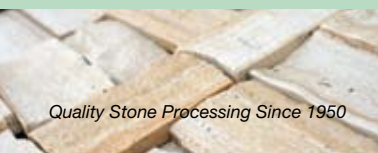



HDS70 Dimensions:

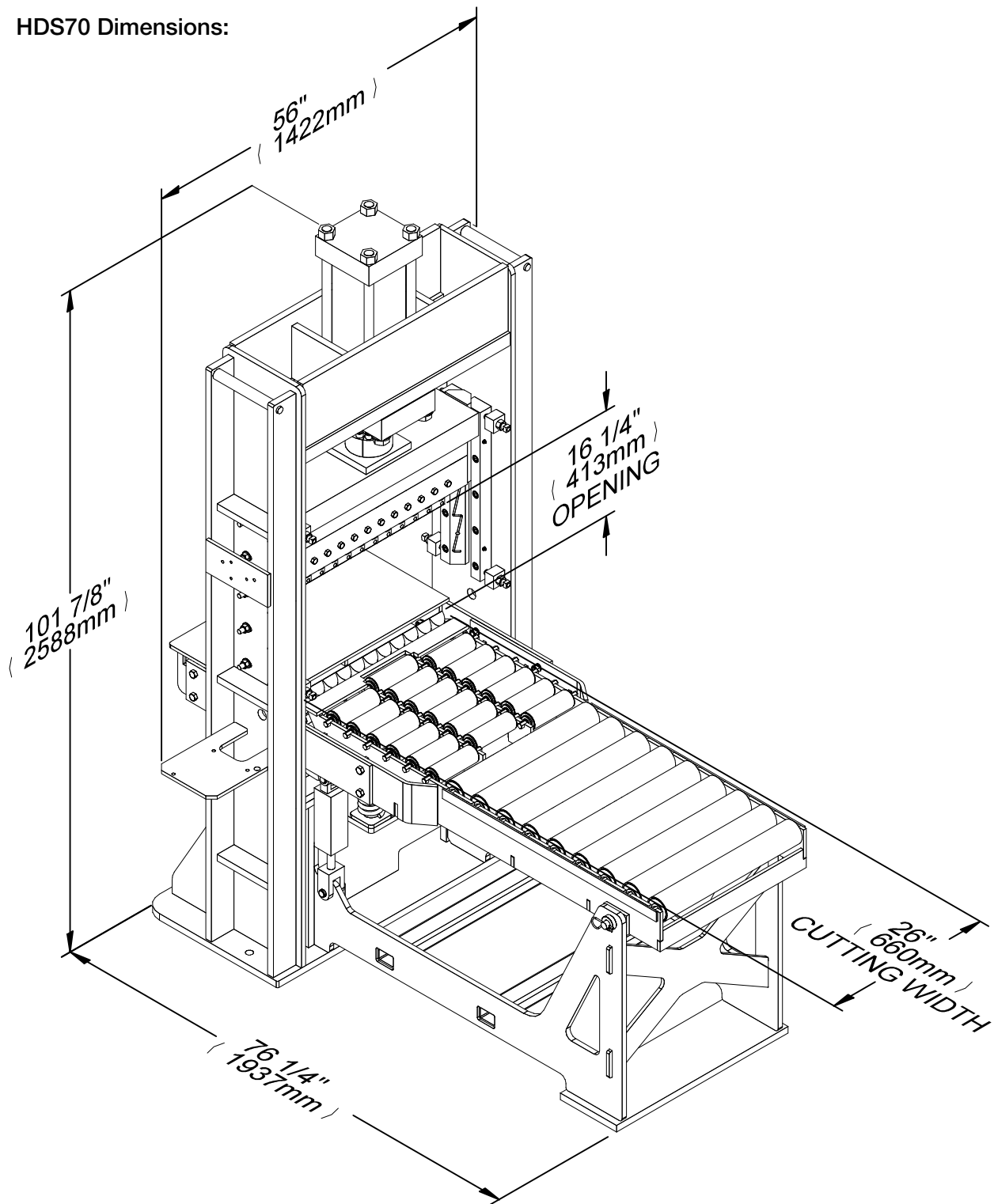



M50 Mobile Stone Splitter

Portable production wherever you need it!



Features:

- 50 tons of mobile cutting force
- Process stone 32" wide up to 10" thick
- 25HP V-Twin gasoline engine
- Patented folding mast
- DOT Approved
- Single axle for greater maneuverability
- Easy transport, set-up and tear down
- Fully hydraulic design for ow maintenance

The **Stone Mason M50 Mobile** is a small, heavy duty production machine made for moving easily to the job. With 26-inches of cutting teeth, a 32-inch wide opening by 10-inch high opening, the HDS is well suited for processing landscape stone including flagstone, river rock, brick, block, natural stone veneer and more.

The M50 incorporates a unique pivot system allowing the operator to hydraulically lower the mast down onto the conveyor, thus lowering the center of gravity and providing a safer towing package.

Built on a specially designed, DOT approved trailer, the M50 is equipped with leveling jacks, leaf spring suspension, electric brakes, a safety breakaway system and all required lighting and can be set up and cutting stone in a matter of minutes. The gasoline engine enables the cutter to be taken to remote areas that may not have access to electricity.

For more information call or visit: 800-350-9313 www.CeeJayTool.com





M50 Dimensions:

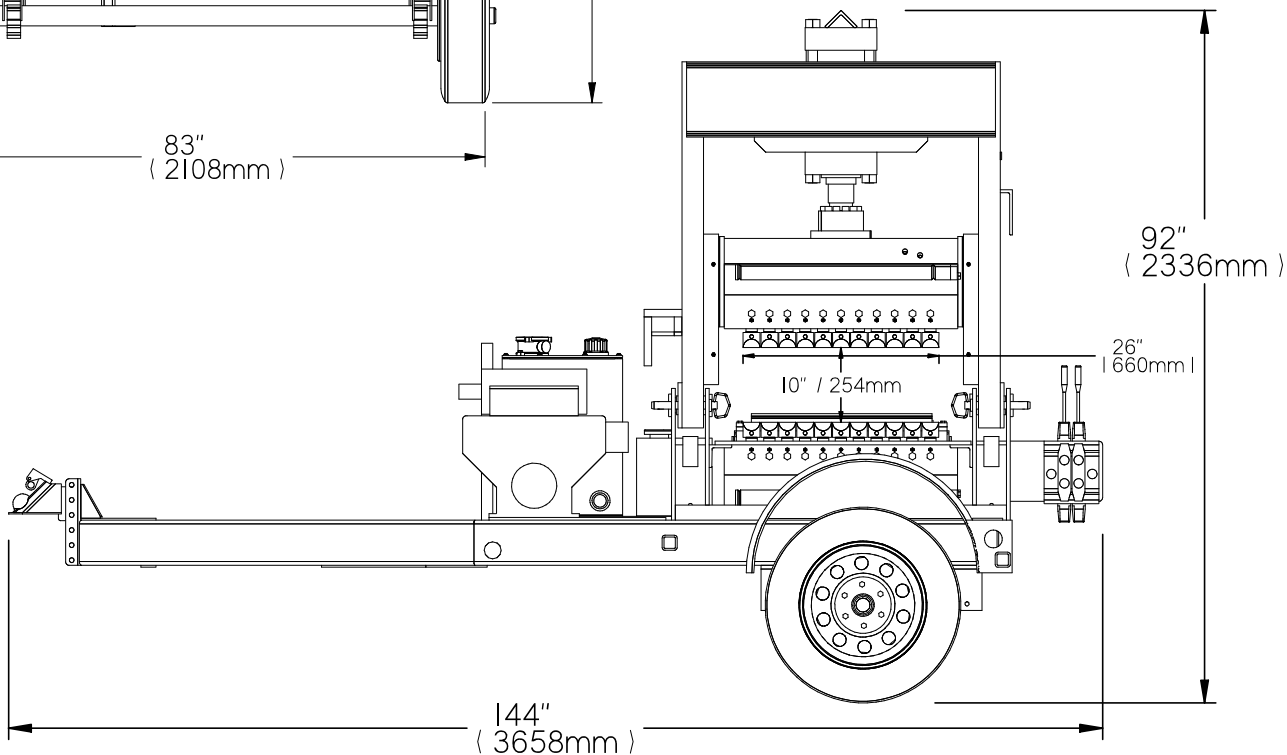
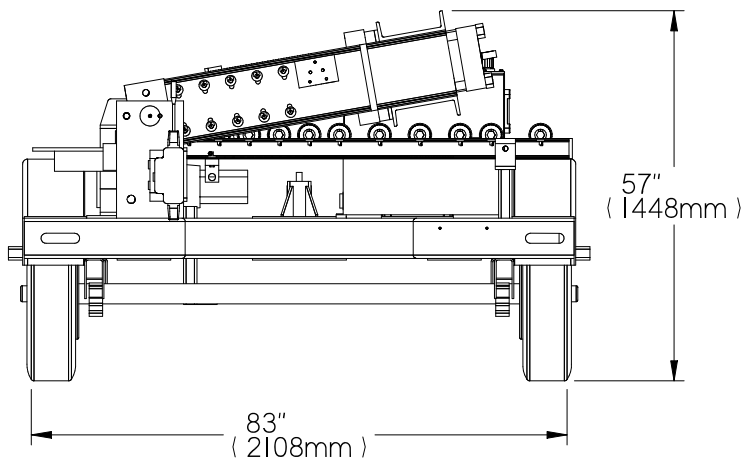
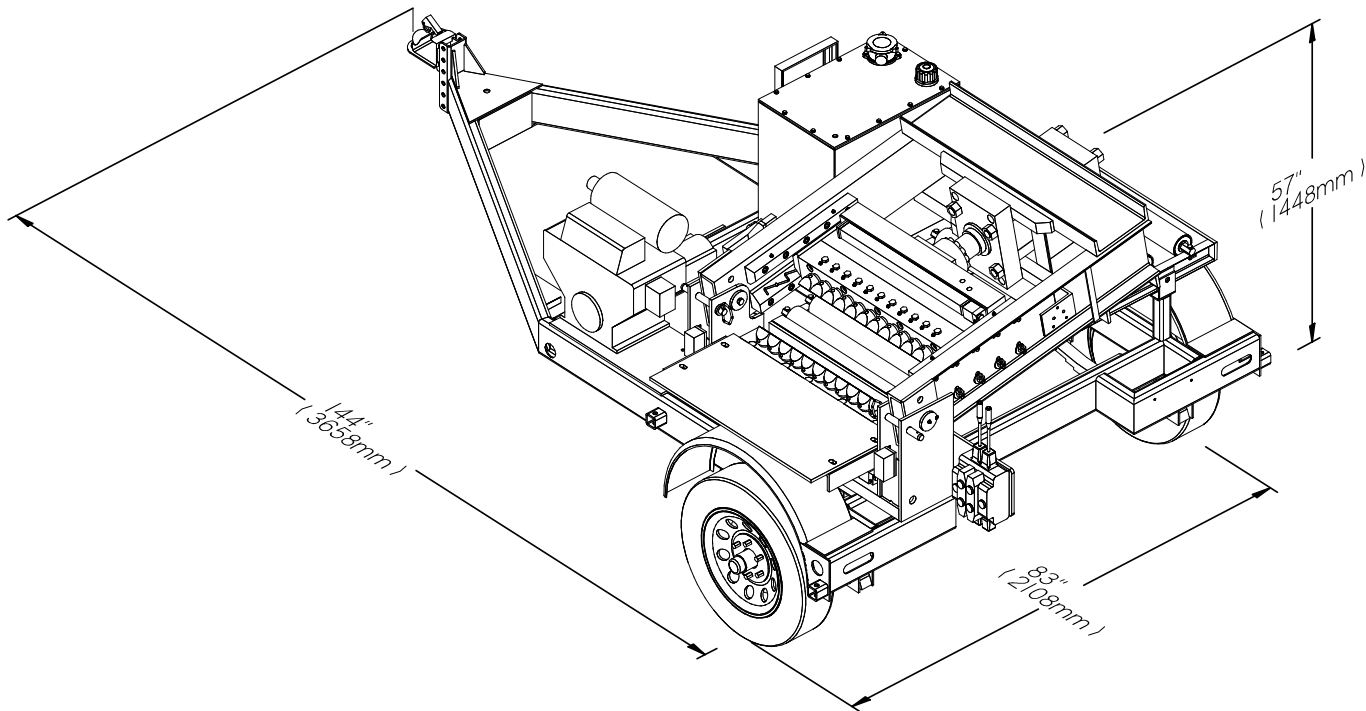



Stone Mason Trimmer

Productive Trimming Where You Need It!



The **Stone Mason Trimmer** is a light weight portable tool designed for the landscape installer, mason contractor or production shop to eliminate the need for hand tools and sawing equipment addressing the need for accurate cutting and trimming of a **wide variety of man made** and **natural thin veneer** products. With its safe simple operation it requires minimal skill and training while adding value to any project through increased productivity, reduced injuries and low operating cost. Returns can also be seen through the preservation of materials by a reduction in waste and better materials utilization over other methods.

The Mason Trimmer incorporates an innovative independent hydraulically driven tooth design with a fixed lower blade to facilitate the cutting of a broader range of materials making it the most versatile cutter in its class. Additionally the multifunction integrated hydraulic accelerator provides improved cut speeds and pressure regulation while isolating the tools hydraulic system from damaging contaminants. Its 100 pound weight and compact size make it easy to transport and set up anywhere compressed air @ 100 PSI (12 CFM) is available.

Stone Mason Trimmer Features:

- Lightweight and portable design
- Durable all aluminum and steel construction
- Hydraulic design for low maintenance operation
- Trims man made and natural products
12 inches wide up to 2 inches thick
- Over 12 tons of cutting force
- Reversible hardened steel bottom blade
- Seven hardened steel contouring upper teeth
- Fast cycle times with integrated accelerator
- Made in USA

*For more information call or visit:
800-350-9313 www.CeeJayTool.com*